

| ITEM | QTY | BILL OF MATERIAL |
|------|-----|------------------|
| 1    | 1   | WING, 2-PRONG    |
| 2    | 1   | WING, 3-PRONG    |
| 3    | 1   | PIN, KNURLED     |

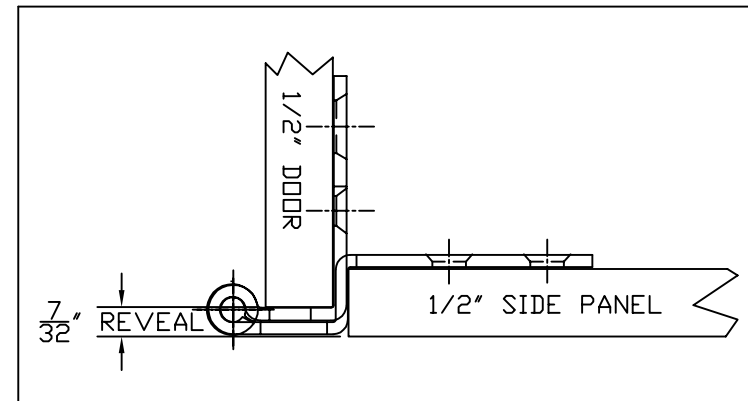
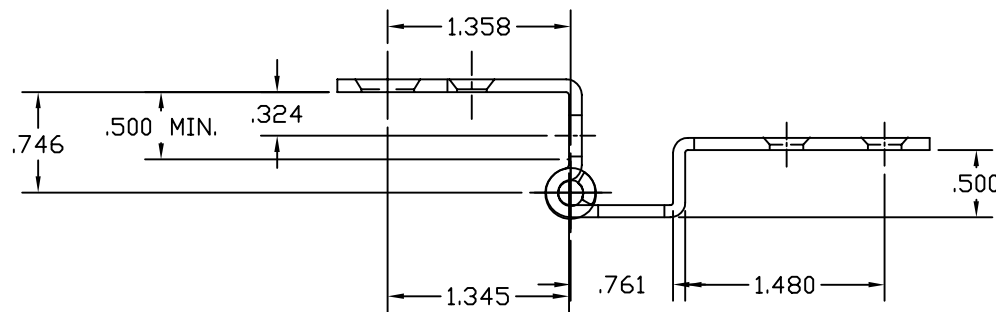
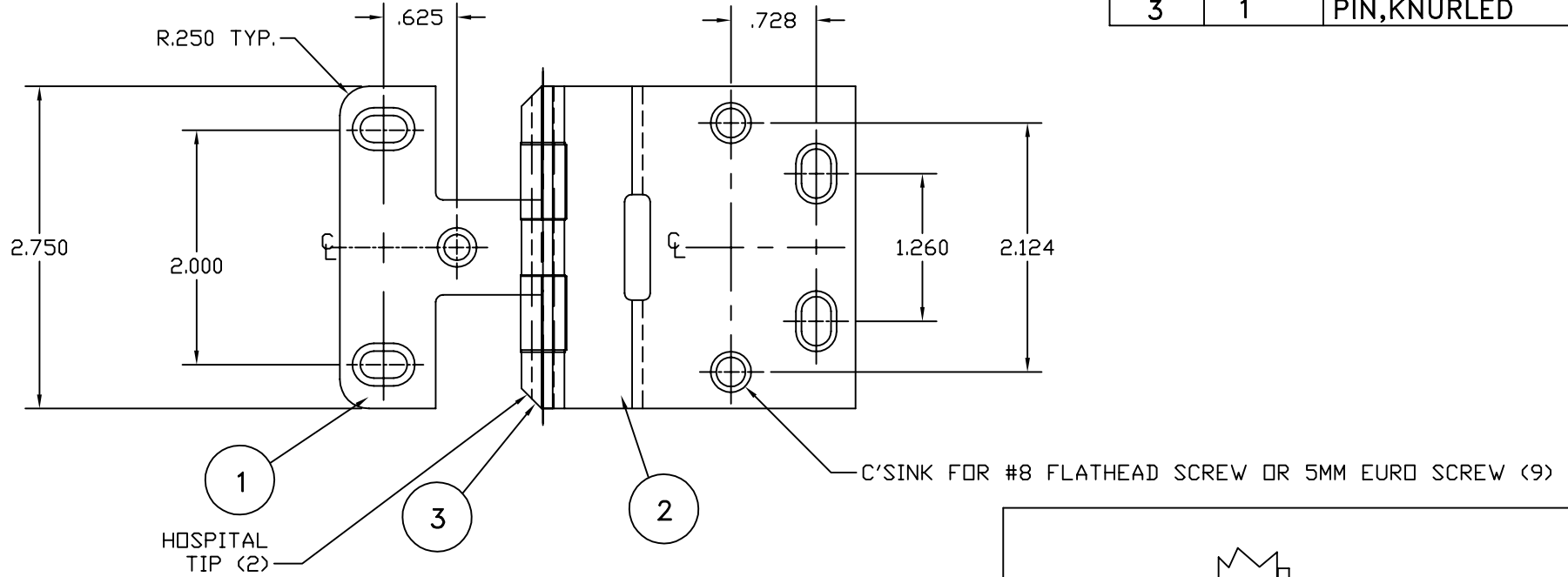

# APPLICATION DRAWING

|                              |      |
|------------------------------|------|
| CUSTOMER P/N (IF APPLICABLE) | REV. |
|------------------------------|------|

THIS PRINT IS THE PROPERTY OF RPC AND ITS DUPLICATION, RETENTION OR TRANSMITTAL TO OTHERS IS PROHIBITED WITHOUT PRIOR CONSENT.



| ECR# | REV. | DESCRIPTION | BY | DATE |
|------|------|-------------|----|------|
|      |      |             |    |      |
|      |      |             |    |      |
|      |      |             |    |      |

|          |            |                   |         |                                                 |          |
|----------|------------|-------------------|---------|-------------------------------------------------|----------|
| MATERIAL | SEE B.O.M. | SCALE (SIZE)      | 1:1.5   | SHT NO.                                         | OF       |
| FILENAME | 8314APP    | MAT'L WT (LBS/EA) |         | PART DESCRIPTION<br>HINGE, OVERLAY, 1/2" X 1/2" |          |
| DRAWN BY | MAB        | DATE              | 3/21/05 | PART NUMBER                                     | 8314-APP |
|          |            |                   |         | REV.                                            |          |